

Automatic Transfer Switch Equipment (ATSE) L2S Series

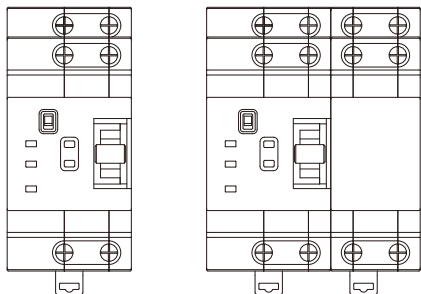

Important Notes:

- Please read this manual carefully before installing or operating the product. If you have any questions, please contact our company.
- Unauthorized disassembly of the product is strictly prohibited to prevent instrument failure or malfunctions.

DIN Rail Installation

1. Insert the upper end of the ATSE base into the DIN rail.
2. Push the lower end of the ATSE base into the DIN rail until the snap fastener locks securely.

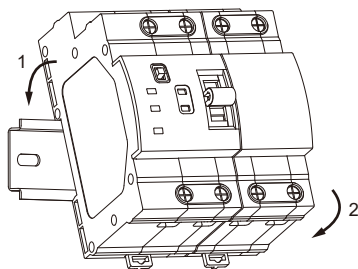

Wiring

1. The ATSE is equipped with screw-type terminals, each with a width of 7.4 mm, suitable for copper wires with a cross-sectional area of 1 to 16 mm².
2. When wiring, strip the wire to a length of 12 to 13 mm; it is recommended to use a duckbill-shaped terminal for secure connection.
3. Tighten the screws with a recommended torque of 2.5 Nm to ensure proper tightening without damaging the terminals.

DIN Rail Disassembly

1. Insert a screwdriver into the round hole of the DIN rail snap fastener at the bottom of the ATSE.
2. Use a screwdriver to pry the DIN rail snap fastener downward.
3. Tilt the ATSE upwards and remove it from the DIN rail.

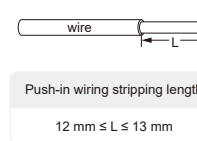
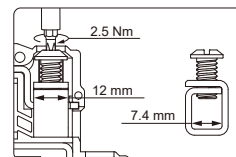
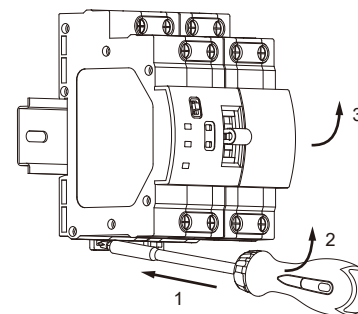

Product Overview

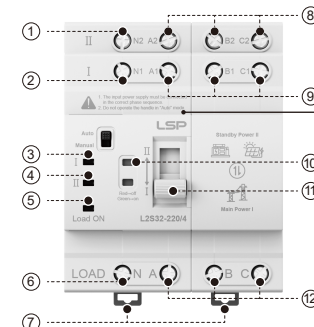

NOTE:
1. The input power supply must be connected in the correct phase sequence.
2. Do not operate the handle in "Auto" mode.

- | | | |
|------------------------------|----------------------------|--|
| ① Standby power neutral wire | ⑤ Load power | ⑨ Main power live wire |
| ② Main power neutral wire | ⑥ Load output neutral wire | ⑩ Closing indication (Green: ON, Red: OFF) |
| ③ Main power supply | ⑦ Din-Rail buckle | ⑪ Manual operation handle |
| ④ Standby power supply | ⑧ Standby power live wire | ⑫ Load output live wire |

Main power supply

When the power supply is abnormal (under voltage or over voltage state) Flashing indicator light

Standby power supply

When the power supply is abnormal (under voltage or over voltage state) Flashing indicator light

Dimensions

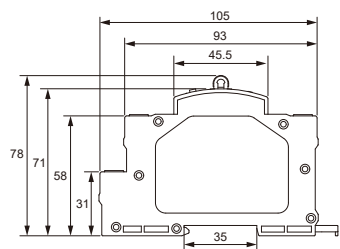
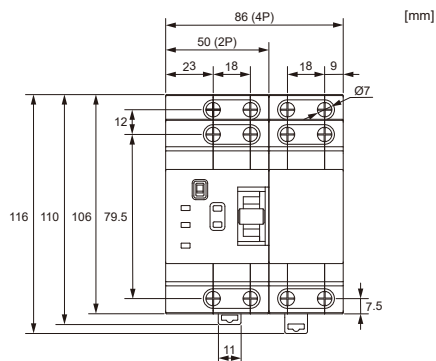

Important Notes

- **The input power supply must be connected in the correct phase sequence.**
- **Avoid using single-pole breakers for neutral/live control lines.**
- Switch neutral and live lines simultaneously to prevent malfunctions.
- Prefer automatic mode for reliability; excessive manual use can cause contact wear.
- Switch to manual mode only after power disconnection for maintenance.
- Keep in automatic position normally; return to it after manual use.
- For dual-power ATSE, minimize switching and allow at least 1 minute between tests.
- Only qualified personnel should operate the ATSE while powered.

Working Conditions

- Altitude: Up to 2000 meters
- Operating Temperature Range: -5°C to +40°C (24-hour average must not exceed +35°C)
- Storage Temperature Range: -25°C to +55°C (transient peaks up to +70°C)
- Operating Humidity: Up to 50% at +40°C; up to 90% at +20°C (condensation prevention required)
- Contamination Level: Level 3
- Protection Rating: IP30
- Overvoltage Category: Category III (main circuit), Category II (control/auxiliary circuits)
- Mounting Orientation: The ATSE can be installed vertically or horizontally in cabinets. For specific installation requirements, please get in touch with us.

Cautions

- Professional Installation: Only qualified professionals should install and commission the Automatic Transfer Switch Equipment (ATSE).
- Installation Environment: Install the ATSE on a clean, dry surface with adequate airflow.
- Electrical Connections: Ensure all connections are secure to prevent overheating and fire hazards.
- Avoid Neutral-Ground Bonding: Do not connect the neutral line to the grounding system, as this can create hazards.
- Follow Local Regulations: Ensure compliance with applicable local electrical codes for safety and reliability.

Adhering to these guidelines ensures the safe operation of the ATSE.

Maintenance

- Professional Inspection: Engage qualified personnel to regularly inspect the ATSE, verifying proper operation.
- Routine Cleaning: Periodically remove dust and debris to ensure optimal performance.
- Electrical Contact Check: Inspect electrical contacts for wear or damage and tighten any loose connections to maintain reliable operation.
- Humidity Control: Maintain a dry environment to prevent moisture-related malfunctions.
- Insulation Testing: Routinely test insulation resistance to verify adherence to safety standards.
- Proper Storage: Store the ATSE in a protected environment, shielded from dust, humidity, and physical harm when not in use.

Adhering to these refined maintenance procedures ensures the safe and effective functionality of ATSE.

Easy Installation Instructions

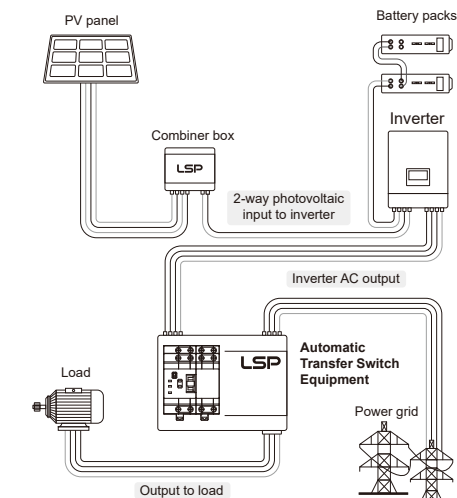

Wenzhou Arrester Electric Co., Ltd.

5th FL, Bldg 2, No. 888 Liujiang Road, Liushi, Yueqing 325604 Zhejiang, China
Email: sales@lsp.global
Website: <https://lsp.global/>

